

GASENGINES "4TG"

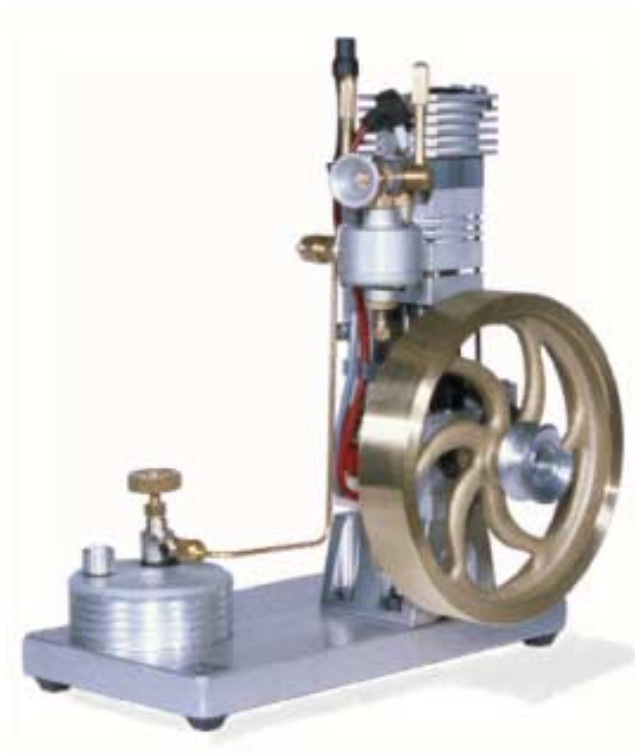

ASSEMBLY PLAN



4TG ASSEMBLY INSTRUCTIONS

Some of the components are pre-assembled as modules.

1. Assembling the crank journal bearing

- 1.1 Push both of the ball-bearings (22x10x6) onto the crankshaft and insert them into the two bearing plates (4).
- 1.2 Engage the washer springs (4.1) in the notches of the external side of the base plates (see diagram).
- 1.3 Loosely screw on the base plate (5) true to side with 2 M3 screws and retaining rings.

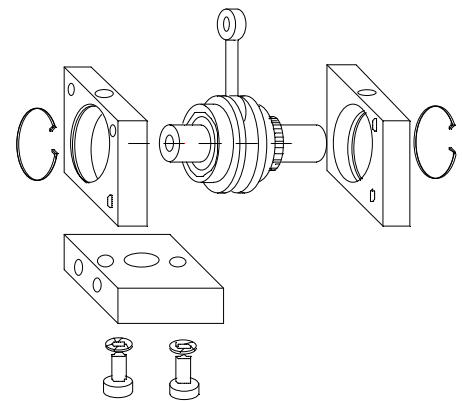

2. Assembling the crank guide

- 2.1 Screw down the right guide column (6) with M4 to the bearing plate.
- 2.2 Insert the crank guide (cross clamp (9)) into the guide rod.
- 2.3 Hang the con-rod (7) with the parallel pin (9.1) and the piston rod (8) in the crank guide.
- 2.4 Screw the second guide column (6) through the crank guide and onto the bearing plate (tighten with M3 and lock nuts)
- 2.5 Screw the cylinder plate (3) with the M3 screws and retaining rings onto the guide columns (tighten moderately): the piston must go through the central borehole.
When screwing down, the crosshead should be at the top, at the side of the cylinder plate.
- 2.6 Push the crosshead down to the bearing plates once again. Loosen the M3 screws on the base plate and tighten them once again. The crank guide and crosshead should go back and forth easily with a little allowance (to account for expansion when hot). Even when the base plate and the cylinder plate have been screwed moderately tightly, by lightly striking the cross head with a plastic hammer or screwdriver handle, the guide columns can be aligned in the middle. Afterwards the screws should be tightened.

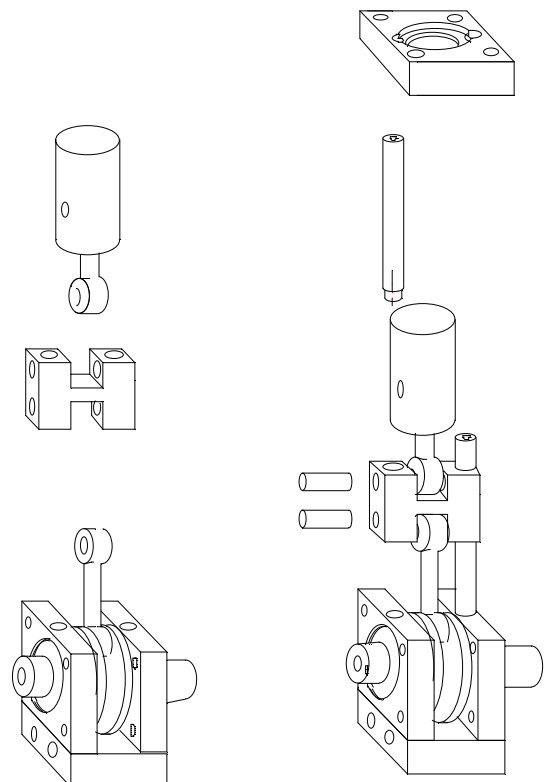

3. Assembling the cylinder unit

- 3.1 Insert the Teflon insulation (2.1) in the cylinder case.
- 3.2 Insert cylinder (2) into the cylinder case, paying attention to correlation of the screw connection with the cooling head.
- 3.3 The cylinder unit assembled in this way should now be mounted on the cylinder plate screws (M4x25.) At the same time the piston should be inserted in the cylinder. Pull the screws more tightly over the cross.
- 3.4 Once again monitor that the motor unit is running smoothly and if required remove any tension.

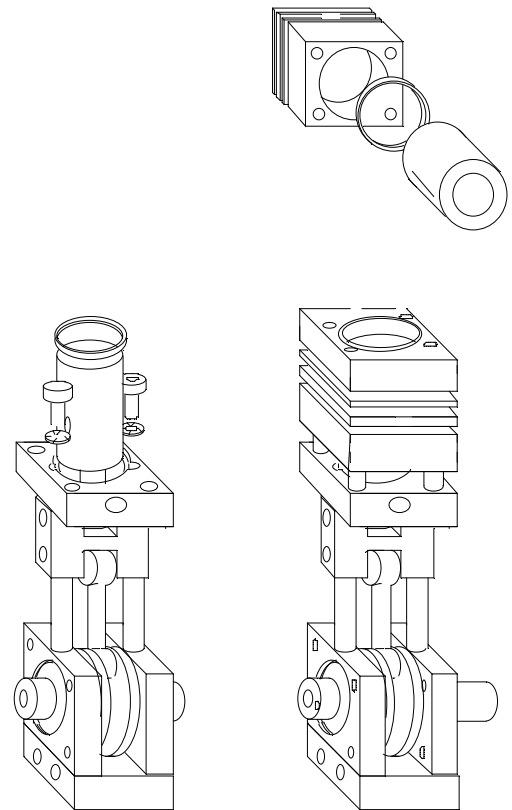

4. Assembling the ignition clamp

- 4.1 Screw ignition angle support with 4 countersunk screws onto the left bearing plate.
- 4.2 Screw the detonator with a spacer and M3 screw onto the fixing bracket. Screw an M4 x 10 adjustment screw with lock nut into the support.

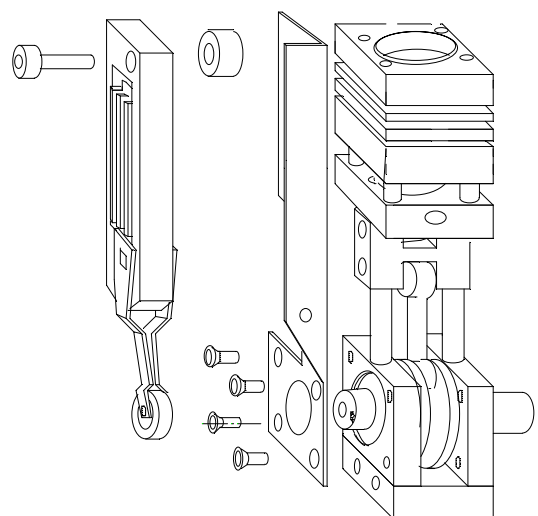

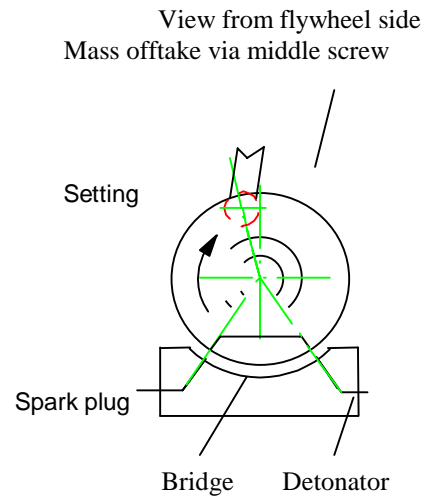
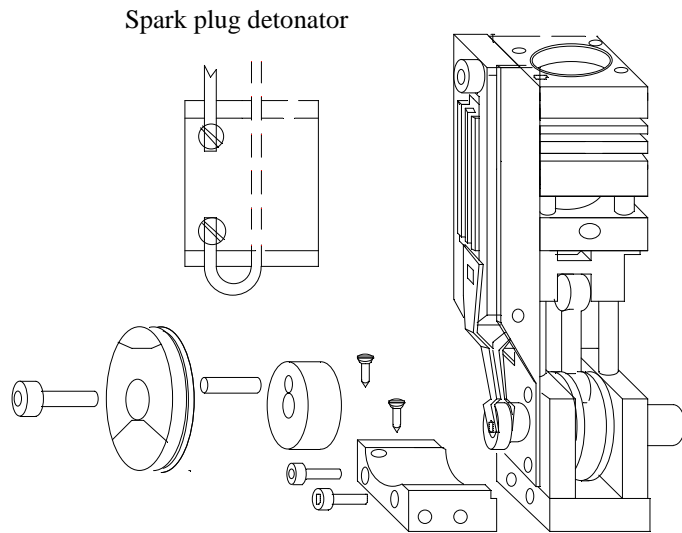

5. Assembling ignition unit.

- 5.1 Mount stator (22) on the base plate (5). 2 x M3 x10
- 5.2 Push the cable from the detonator through the long borehole on the stator.
- 5.3 Push the (red) cable into the short borehole on the stator
- 5.4 Turn the 2 self-tapping screws through the pre-drilled holes up to the heads, and in the process the self-tapping screws will penetrate through the cable insulation and create electrical contact.
- 5.5 Place the catch pin (20.1) (1.5x 13) into the borehole on the crank shaft.
- 5.6 Push the eccentric (20) onto the catch pin.
- 5.7 Screw the rotor (21) with the M4 x 15 screw through the eccentric (20) onto the crank shaft. The rotor should be screwed in such a position that the "bridge" in the rotor is facing down, in other words above the self-tapping screws when the camshaft has reached the top dead centre (about 5 degrees before), so that the high voltage can jump over (with the spark plug mounted).
- 5.8 Turn the M4 screw in the bracket so far in the direction of the detonator that when the camshaft turns around, the high voltage jumps over safely at the rotor.

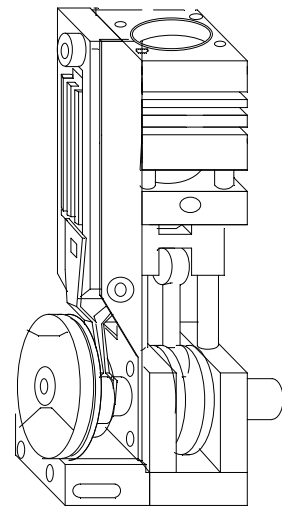

6 Assembling the flywheel and the base

- 6.1 Fasten the bearing shield loosely with two M3 screws to the bearing plate.
- 6.2 Press in the ball-bearings and pull the bearing shield tight.
- 6.3 Place the pre-mounted flywheel with the starter wheel onto the free end of the shaft and fasten it with an M6 x 40 screw.
- 6.4 Mount the fastening element on the motor (M5 screw).
- 6.5 Insert the cylinder head gasket into the recess in the cylinder.

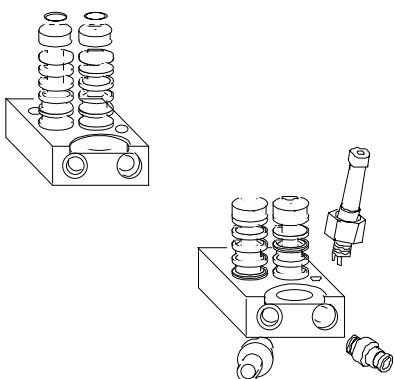
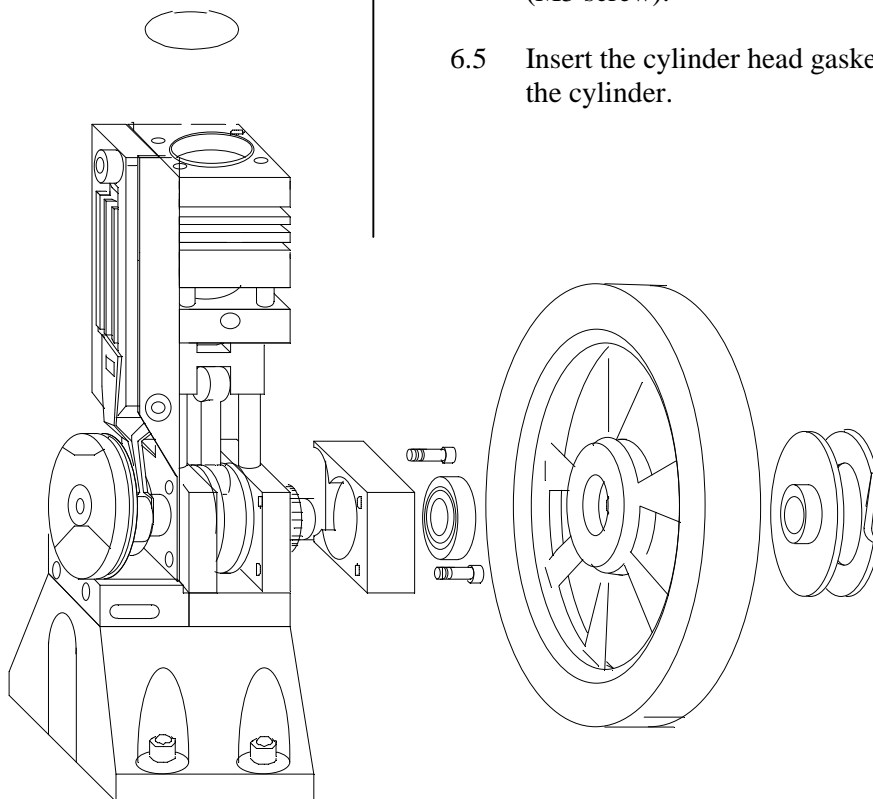

7. Assembling the cylinder head

- 7.1 Insert valves and springs and hang them with retaining rings.
- 7.2 Screw in spark plug.
- 7.3 Screw in both connecting pieces and pull them tight.

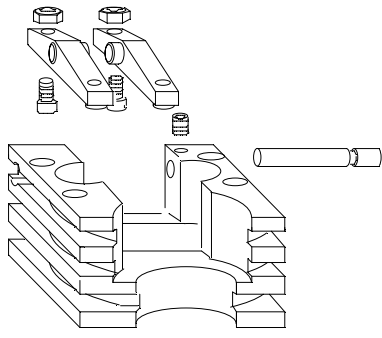

8 Assembling the cooling head, the cylinder head and the rocker arms

8.1 Place the cylinder head and the cooling head on the cylinder case and fasten it with 4 M4 screws.

8.2 Assemble the rocker arms true to side (the short female connector side facing outwards).

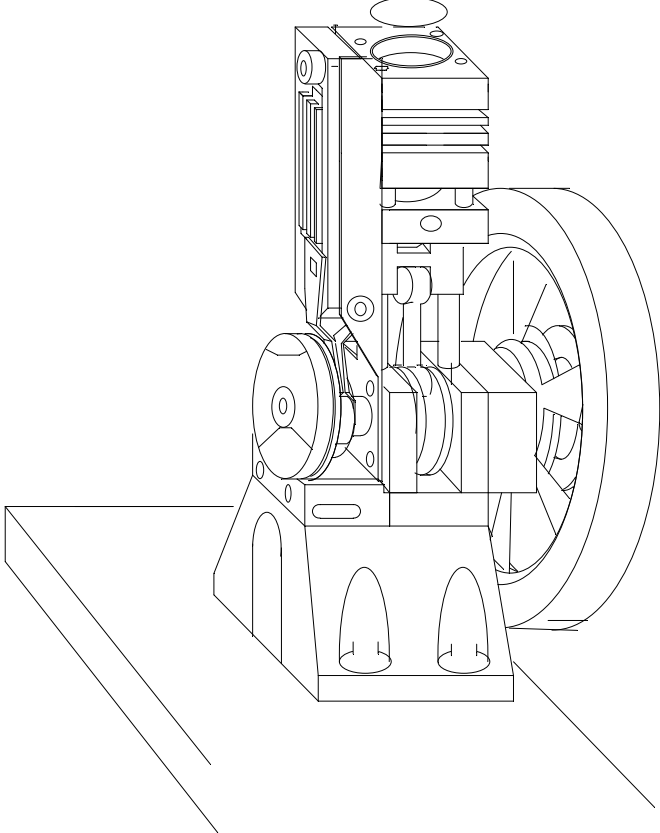
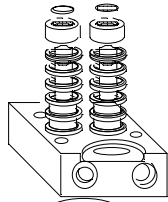

8.3 To do this push the stud into the side of the cooling head and fasten tightly with the M3 stud bolt.

8.4 Screw in the M4 adjusting screws at the bearing arms and put on nuts.

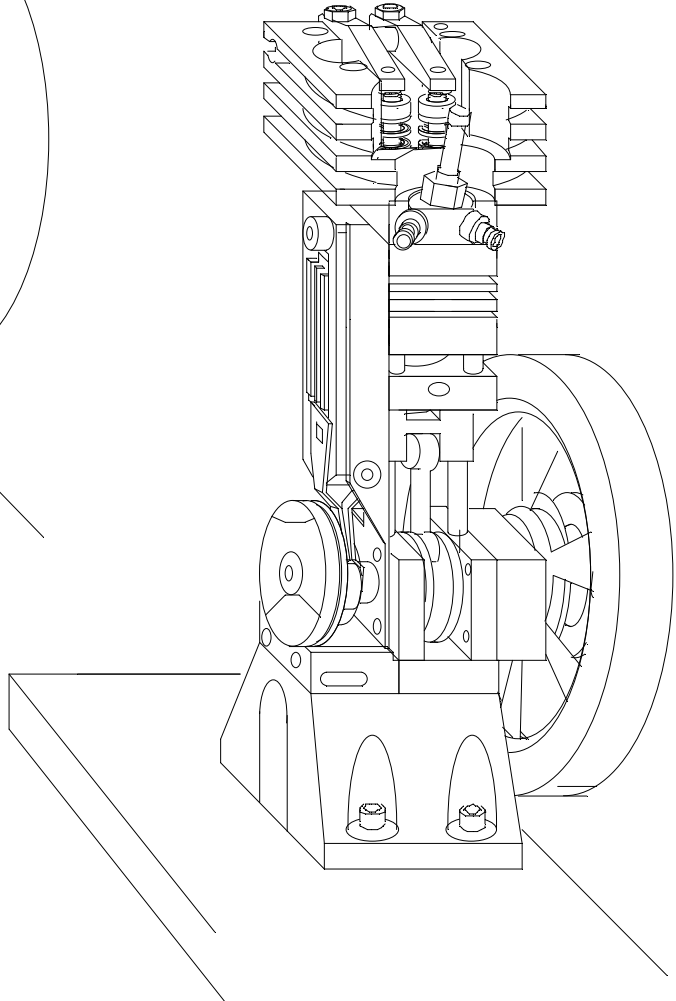

9 Assembling the camshaft box

- 9.1 Insert the camshaft true to side in the bearing bush on the left side plate.
- 9.2 Place the right side plate on the camshaft.
- 9.3 Insert both slides from below into the slide plate and connect with 2 M3 screws with the side plates.
- 9.4 Screw the cog onto the bevelled side of the camshaft and tighten it.
- 9.5 Now fasten the entire camshaft box onto the two bearing plates on the motor.

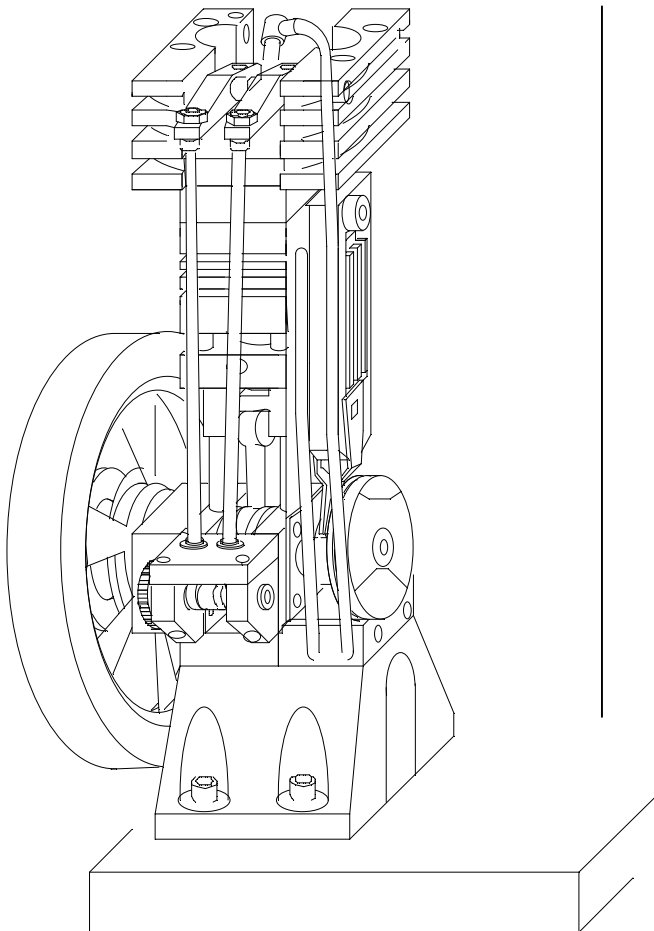
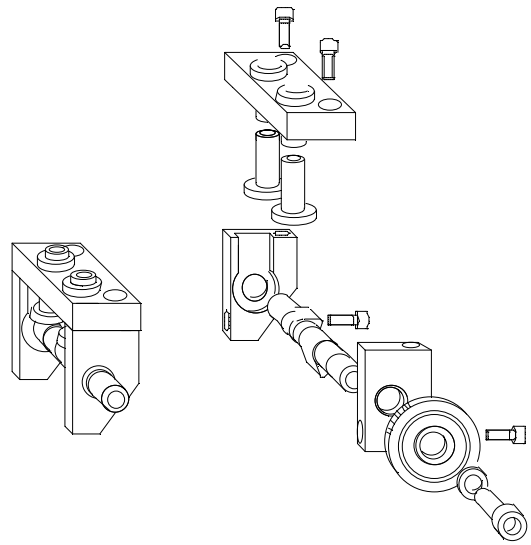

10 Assembling the valve rods

- 10.1 Screw in both M4 screws entirely on the rocker arms.
- 10.2 Turn the camshaft or the motor such that the slides are at the very bottom.
- 10.3 Press the rocker arms downwards at the valve end so that they spring in, and in this position insert both valve rods.
- 10.4 Unscrew both M4 screws at the rocker arms far enough for the valve allowance to be 0.3-0.5 mm.
- 10.5 Only keep screws fastened with lock nuts.

11 Set operating times of the valves

- 11.1 To set the operating times both M3 connecting screws on the camshaft box and the bearing plates of the motor should be loosened far enough for the cogs of the camshaft and the crank shaft to no longer engage.
- 11.2 The position of both shafts should be set such that the opening and closing movements of the valves complement each other, in other words that the exit valve closes when the entrance valve opens.
- 11.3 The camshaft box should be screwed tight once again in this position.

12 Assembling the carburettor

- 12.1 Insert the gas/air lever into the designated openings in the carburettor tube and tighten with nuts.
- 12.2 Screw the idle nozzle into the carburettor tube.
- 12.3 Screw the connection for the idle nozzle into the membrane case.
- 12.4 Mount the control valve, valve lever and valve nozzle.
- 12.5 Screw the control valve from inside to join it with the membrane case.
- 12.6 Mount the springs and the main nozzle.
- 12.7 Insert the membrane and fasten the case lid with both clips.
- 12.8 Screw the jump-start respectively the inching device into the lid.
- 12.9 Screw the entire membrane case with the main nozzle into the carburettor tube.
- 12.10 Now mount the assembled carburettor on the connecting piece of the cylinder head.
- 12.11 Using a silicon tube, connect the idle nozzle with the connection to the membrane case.

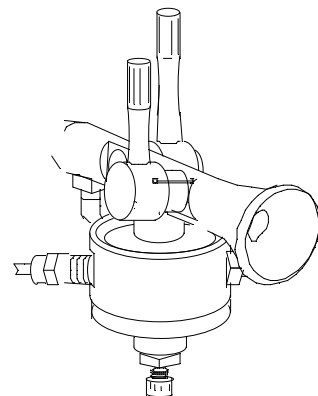
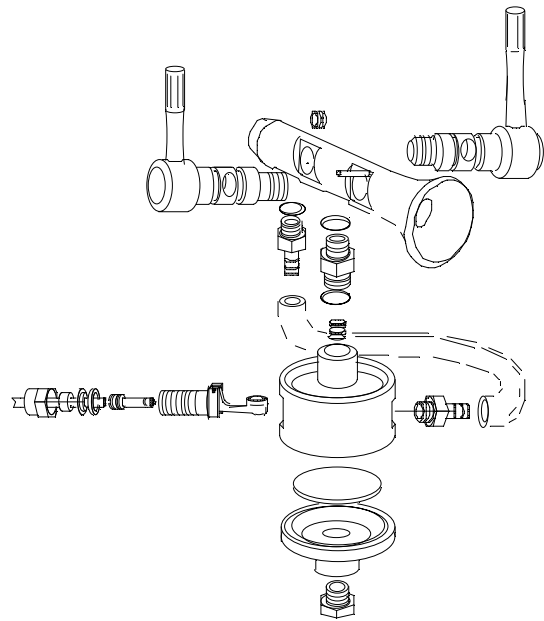

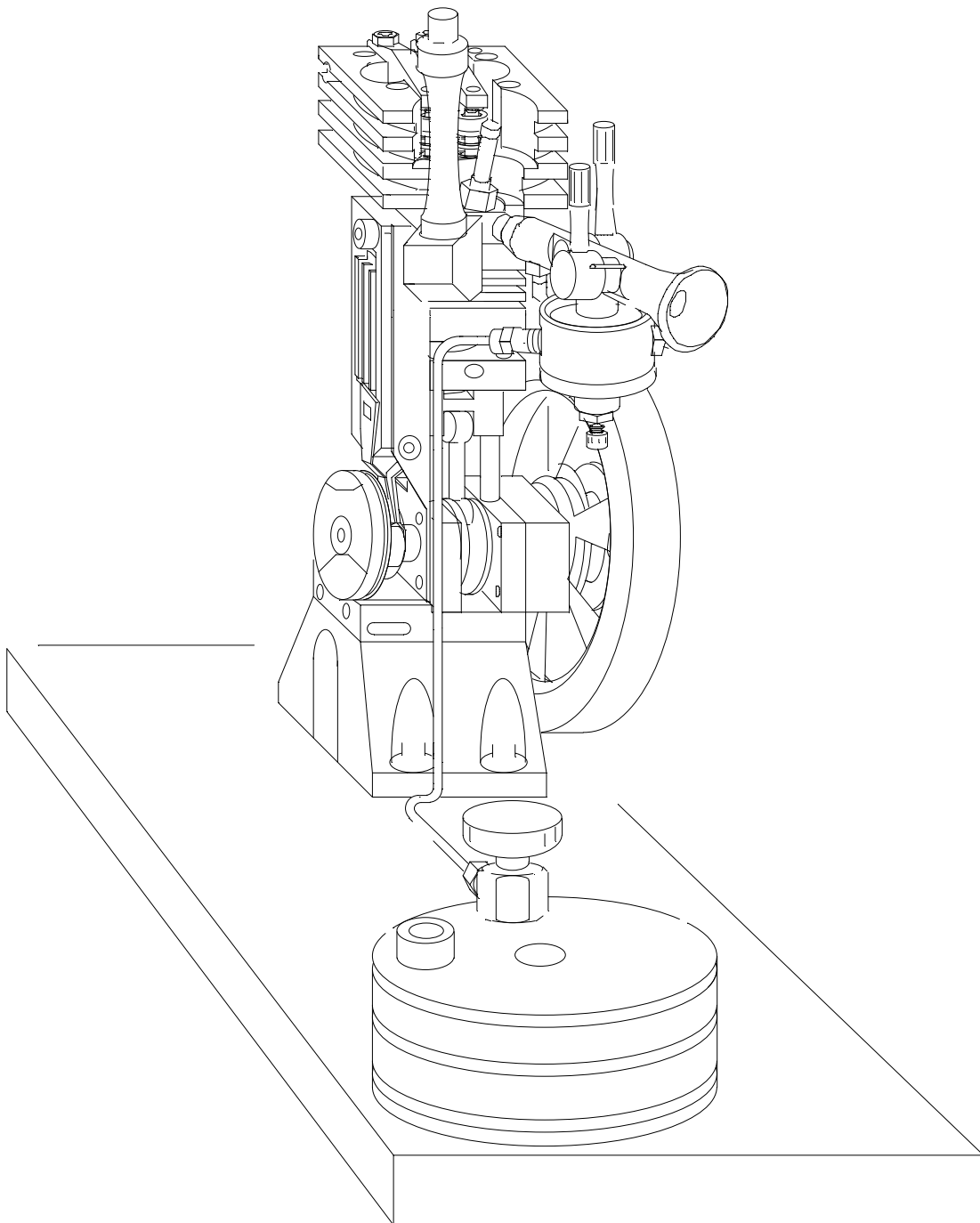

13 Mounting the motor on the base plate

- 13.1 Screw the exhaust tube on the connecting piece on the cylinder head.
- 13.2 Fasten the motor with the base on the base plate.
- 13.3 Mount the tank with the valve on the base plate.
- 13.4 Connect the gas feed to the tank and the motor.

Details 1

The sliding parts, depending on the strain to which they are subject, should be oiled using thin oil without additives.

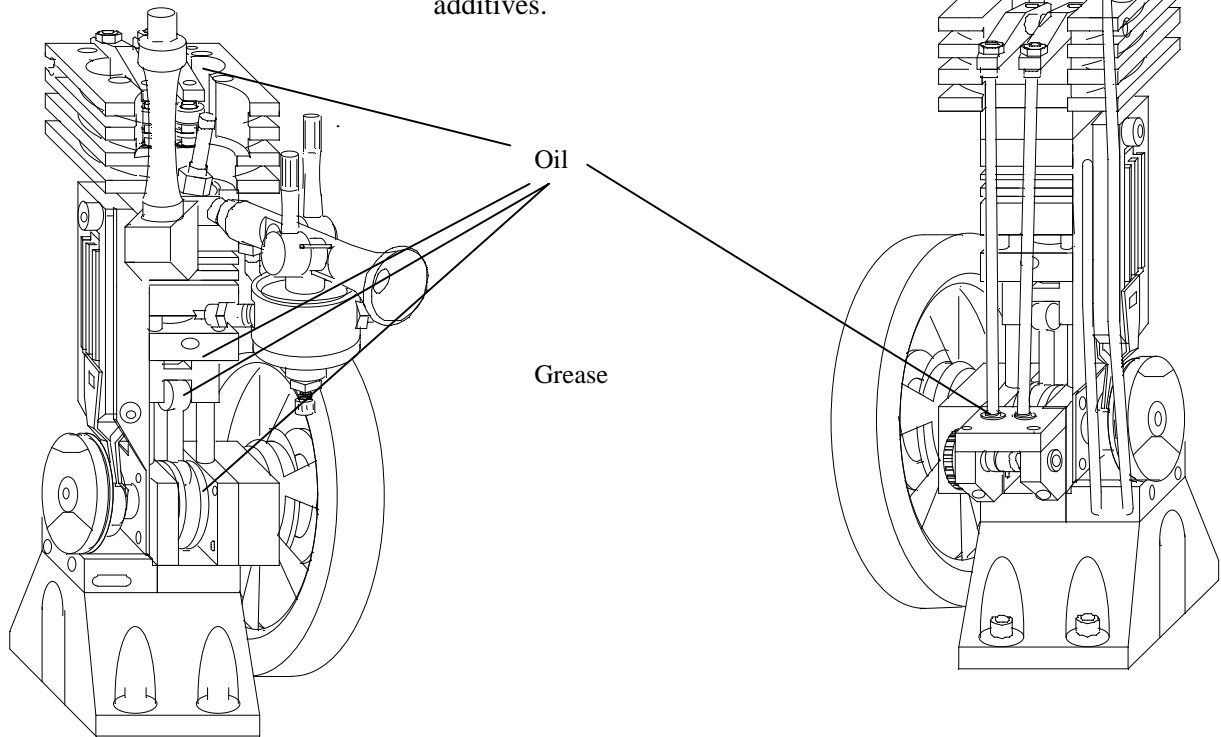

Ignition

If there is no flashover between the stator (22) and the rotor (21), more pressure can be put on the piezoelectric crystals at the set screws (25.3). The time of ignition can be set by loosening the M4 screws and turning the rotor. (Normal = approx. 3-5 degrees before the top dead point)
(Earlier ignition time = faster running)
(Later ignition time = better start)

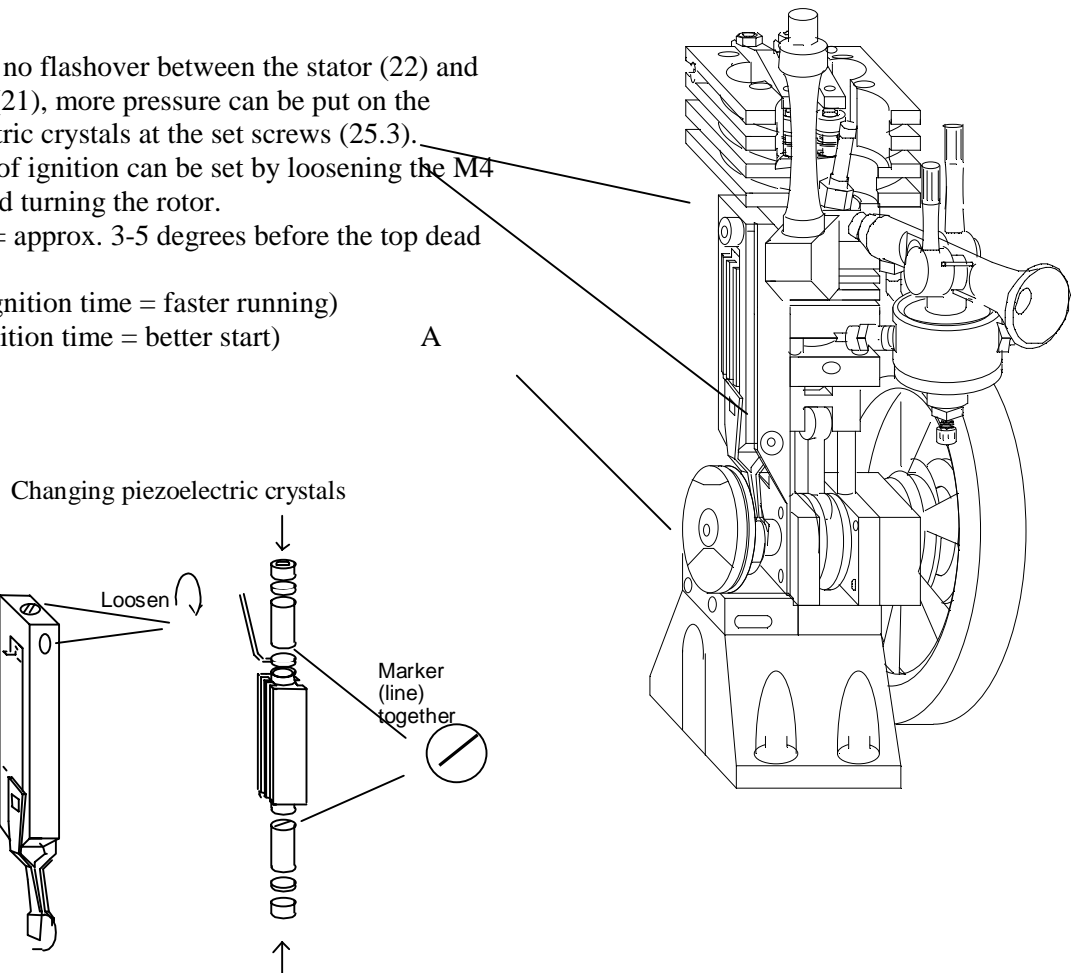

Details 2

Setting control times of the valves

To set the control times the two M3 connecting screws in the camshaft box and bearing plates of the motor should again be loosened far enough for the cogs of the camshaft and the crank shaft to no longer engage.

The two shafts should be placed one on top of the other such that at the top dead point of the crank shaft the opening and closing movements of the valves overlap, in other words so that the exit valve is closing at the same time as the entrance valve is opening.

In this position the camshaft box should be screwed tight once again. (The best control times and offsets may be best determined through experimentation.)

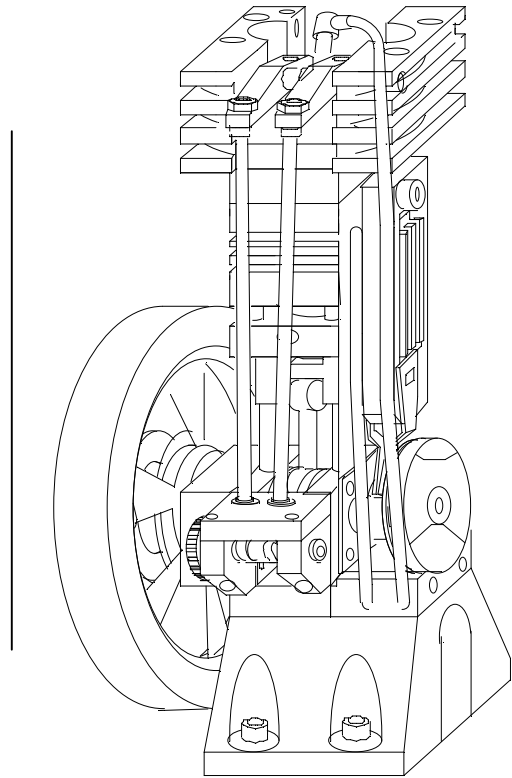

Setting the carburettor

The carburettor nozzle 3 should be screwed into the control valve so far that the valve lever 5 closes securely even when membrane 6 is not activated due to low pressure. (State of rest.)

In order to test this, the carburettor lid should be taken off.

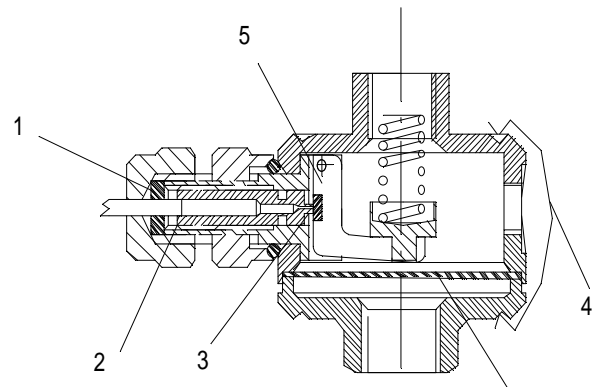
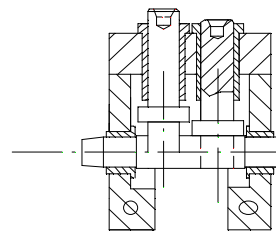

Spray nozzle

Control valve

Valve lever

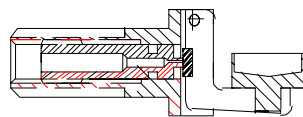
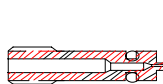

Details 3

Starting the motor

1. Fill tank with gas (propane or butane)
2. Open valve 2 entirely
3. Place air lever 4 in stop position
4. Place gas lever in a vertical position
5. Briefly press jump-start button 5 all the way down
6. Start the motor with the accompanying trigger line.
7. Let the motor warm up in this position (to approx. 70 degrees) and push the air lever a little, depending on temperature (up to approx. 70 degrees), in the direction of the cylinder head, until the motor is running smoothly over its entire speed range (do not allow the motor to run at over 3000 revs/min)

